

PARTS

- (A) VANITY
- (B) LONG LEGS (4)
- (C) MIRROR
- (D) SEAT FRAME
- (E) CUSHION
- (F) SHORT LEGS (4)
- (G) LONG MACHINE SCREWS (12)
- (H) SHORT MACHINE SCREWS (4)
- (I) WASHERS (16)

HARDWARE ILLUSTRATION

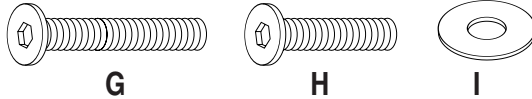

Tools required: Wrench (not included)

Thank you for purchasing this quality product. Be sure to check all packing material carefully for small parts which may have come loose inside the carton during shipment. Separate, identify, and count all parts and metal hardware. Compare with parts list to be sure all parts are present. If any part(s) are missing or damaged, phone, fax, or mail to our Customer Service Department. For efficient and speedy service, please indicate the model number and code letter of part(s) needed.

ATTENTION: SOME NUMBERED PARTS LISTED ON THE INSTRUCTION SHEET MAY NOT BE IN PARTS BAG AS THEY MAY ALREADY BE ASSEMBLED. CAREFULLY CHECK PARTS AND PACKING MATERIALS PRIOR TO ORDERING REPLACEMENTS.

IMPORTANT NOTE: Follow instructions listed below in the proper sequence as numbered to assure fast, easy, and correct assembly.

1. **Note:** Upon opening, thoroughly clean all wood surfaces with furniture polish to remove dust and dirt that may have settled onto finish during shipment.
2. Place Vanity (A) upside down parts on a soft cloth. Insert Long Machine Screws (G) through Washers (I), corners of skirt of Vanity (A) and tighten into Long Legs (B). (See ill. #1)
3. Stand Vanity (A) upright. Place posts of Mirror (C) into notches at rear of Vanity (A). Insert Short Machine Screws (H) through Washers (I) and tighten into back of Vanity (A). (See ill. #2)
4. Insert Long Machine Screws (G) through Washers (I), corners of Seat Frame (D) and tighten into Short Legs (F). (See ill. #3)
5. Your furniture has been handcrafted and skillfully finished by fine craftsmen. Rich, deep antique finishes have been applied which require very little polish. However, should you desire a shinier finish, simply use any good grade of furniture polish, rubbing the finish lightly as it is being applied. Allow to dry and buff lightly with a soft cloth.

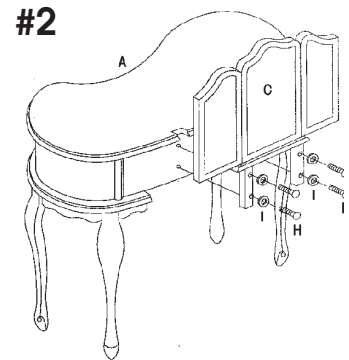
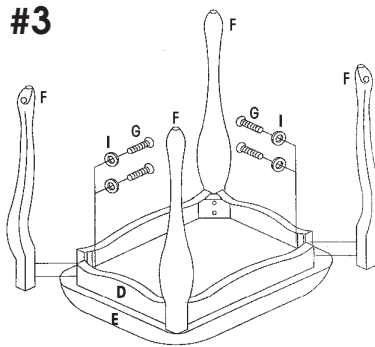
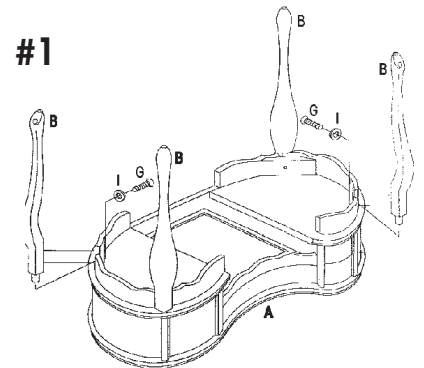

IF YOU HAVE A PROBLEM, WE WANT TO HAVE THE OPPORTUNITY TO MAKE IT RIGHT!

Should there be any missing or defective part(s),

FAX this form to (310) 841-0842

or call Customer Service at (310) 204-2224

Have your model number and part code letter handy.

MODEL NO. E11

© 2000 Powell

Part Letter	Description	Quantity

Name _____

Address _____

Daytime Phone () _____

Reason for Replacement _____

Place of Purchase _____