

Assembly Instructions - Double Floor Cabinet

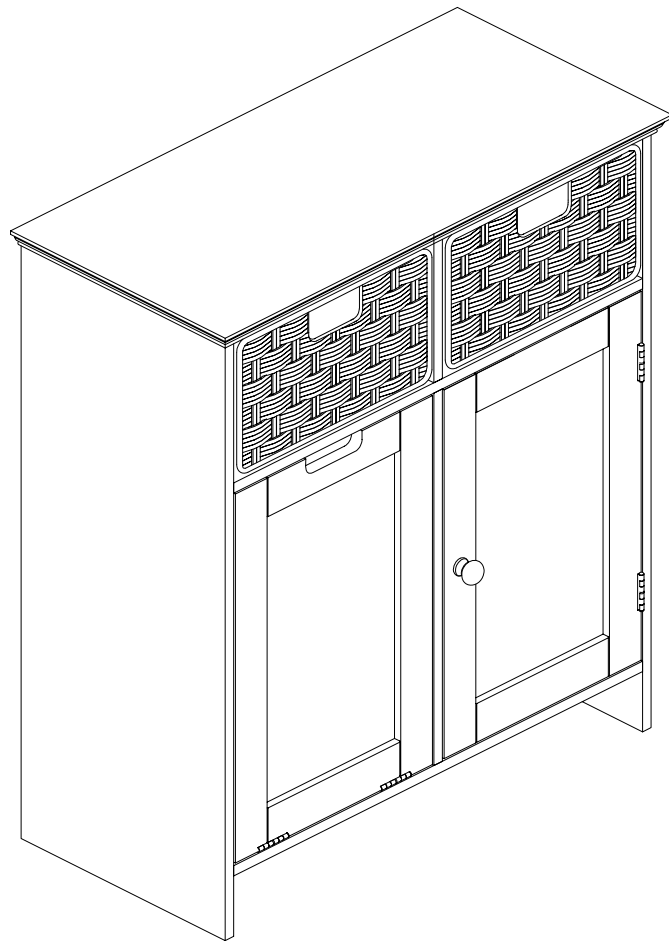

ASSEMBLY INSTRUCTIONS - IMPORTANT

Carefully unpack & identify each component before attempting to assemble. Refer to parts list. Please take care when assembling the unit and always set the parts on a clean, soft surface. If you require any assistance with assembly, parts, please call 866-931-4207.

INSTRUCCIONES PARA ARMAR - IMPORTANTE :

Desempaque cuidadosamente e identifique cada componente antes de tratar de empezar su ensambladura. Verifique la lista de partes. Por favor tenga cuidado cuando arme la unidad y siempre coloque las piezas sobre una superficie plana, suave y limpia. Si necesita ayuda con el armado, por favor llámeda 866-931-4207.

DIRECTIVES DE MONTAGE-IMPORTANT:

Avant de commencer l'assemblage, déballez délicatement toutes les pièces et repérez-les sur la liste des pièces. Procédez avec soins durant l'assemblage et posez toujours les pièces sur une surface propre, douce et lisse. Si vous avez besoin d'aide concernant l'assemblage Svp appel 866-931-4207.

A. Top Shelf Estante Superior Étagère Supérieure	1 PC	
B. Bottom Shelf Estante Inferior Étagère Inférieure	1 PC	
C. Side Panel-Left Panel Lateral-Izquierdo Panneau Laterale-Guache	1 PC	
D. Side Panel-Right Panel Lateral-Derecho Panneau Laterale-Droite	1 PC	
E. Fixed Level Shelf Estante De Nivel Fijo Étagère Fixée	1 PC	
F. Adjustable Shelf Estante Ajustable Étagère Réglable	1 PC	
G. Upper Fixed Shelf Estante Fijo Superior Étagère Fixée Supérieure	1 PC	
H. Lower Fixed Shelf Estante Fijo Mas Bajo Étagère Fixée Inférieure	1 PC	
I. Back Left Panel Panel Izquierdo Trasero Panneau Gauche Arrière	1 PC	

J. Back Right Panel
Panel Derecho Trasero
Panneau Droit Arrière

1 PC

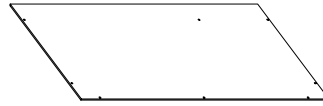

K. Door
Puerta
Porte

1 PC

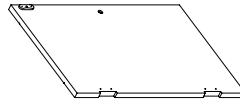

L. Front Barrel Board
Tablero Barril Frente
Étagère Avant

1 PC

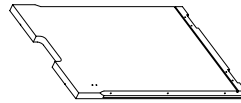

M. Left Barrel Board
Tablero Barril Izquierdo
Étagère Gauche

1 PC

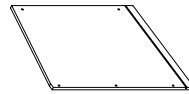

N. Right Barrel Board
Tablero Barril Derecho
Étagère Droite

1 PC

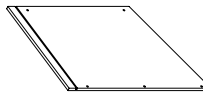

O. Rear Barrel Board
Tablero Barril Trasero
Étagère En Arrière

1 PC

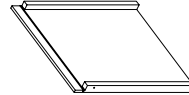

P. Bottom Barrel Board
Tablero Barril Inferior
Étagère Inférieure

1 PC

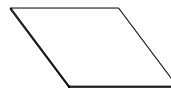

Q. Wall Of Rattan Basket
Pared De La Cesta De Ratán
Mur De Panier De Rotin



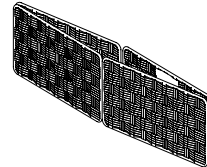







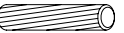
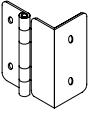

2 PCS

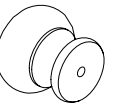

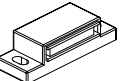
R. Base Of Rattan Basket
Base De La Cesta De Ratán
Base De Panier De Rotin

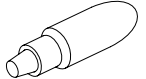
2 PCS

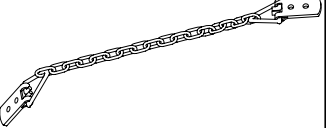

- Note: Do not use Power Screw Driver to turn Cam Lock clockwise 90 degrees to lock
Nota: No utilice el destornillador de fuerza; dé vuelta la cerradura 90 grados a la derecha para cerrar
Note: N'utilisez pas le tournevis de puissance; tournez la serrure de came dans le sens des aiguilles d'une montre à 90 degrés pour fermer
- Note: Do not over drill, Power Screw Driver Not recommended
Nota: No perforé demasiado, no se recomienda el destornillador de fuerza
Note: Ne percez pas trop, Tournevis de puissance non recommandé
- (1). Cam Lock
Cerradura De Leva
Serrure De Came 16 PCS 
 - (2). Cam Bolt
Perno De Leva
Boulon De Came 16 PCS 
 - (3). Cam Lock Cover
Tapa Para Cerradura
Couverture Pour Serrure 16 PCS 
 - (4). Wooden Dowel
Clavija De Madera
Goujon En Bois 10 PCS 
 - (5). Hinge
Bisagra
Charnière 4 PCS 
 - (6). Phillips Screw (Ø 3*10 mm)
Tornillo De Cruz
Vis Cruciforme 16 PCS 
 - (7). Knob
Perilla
Bouton 1 PC 
 - (8). Phillips Screw (Ø 4*22 mm)
Tornillo De Cruz
Vis Cruciforme 1 PC 
 - (9). Magnet
Imán
Aimant 1 PC 
 - (10). Phillips Screw (Ø 3*10 mm)
Tornillo De Cruz
Vis Cruciforme 18 PCS 
 - (11). Shelf Pin
Perno De Estante
Agrafe D' étagère 4 PCS 
 - (12). Glue
Pegamento
Colle 1 PC 
 - (13). Phillips Screw (Ø 3*15 mm)
Tornillo De Cruz
Vis Cruciforme 10 PCS 
 - (14). Chain
Cadena
Chaîne 1 PC 
 - (15). Phillips Screw (Ø 3*12 mm)
Tornillo De Cruz
Vis Cruciforme 4 PCS 

STEP 1
ÉTAPE 1
PASO 1

(Fill dowel hole half way with glue-dowel will push out excess glue-wipe off excess glue)
(Llene mitad del agujero de clavija con pegamento-clavija eliminará el exceso-limpie exceso)
(Remplissez demi de trou de goujon avec colle-goujon éliminera la colle excessive-nettoyez l'excèsif)

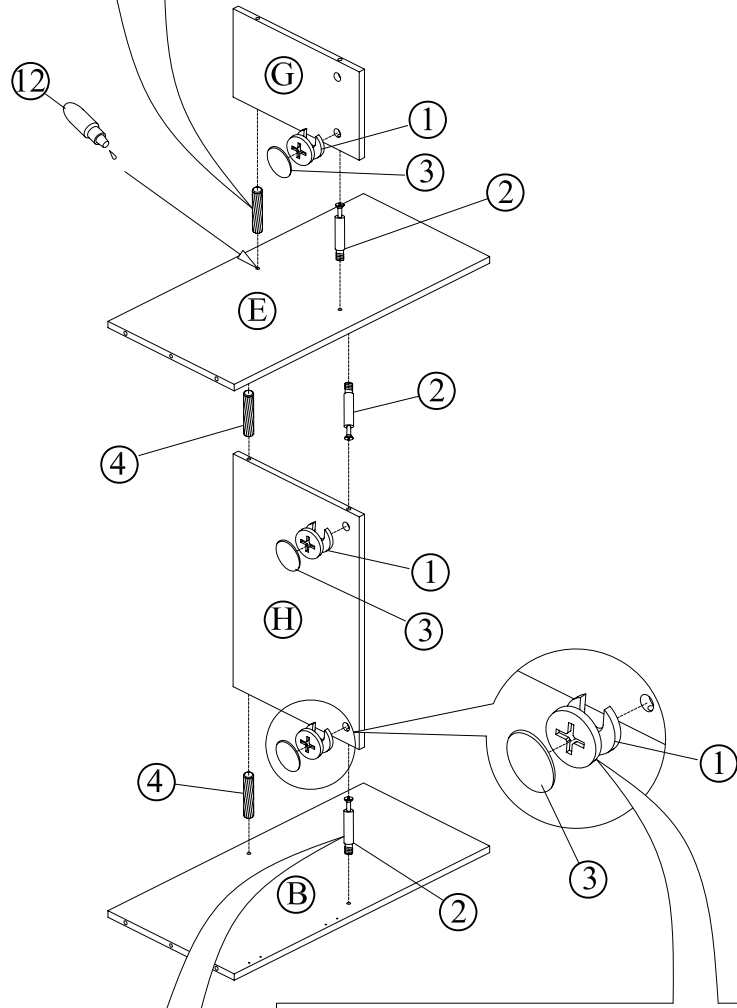

Note: Do not over drill, Power Screw Driver Not recommended
Nota: No perforo demasiado, no se recomienda el destornillador de fuerza
Note: Ne percez pas trop, Tournevis de puissance non recommandé

Note: Do not use Power Screw Drive; turn Cam Lock clockwise 90 degrees to lock
Nota: No utilice el destornillador de fuerza; de vuelta la cerradura 90 grados a la derecha para cerrar
Note: N'utilisez pas le tournevis de puissance; tournez la serrure de came dans le sens des aiguilles d'une montre à 90 degrés pour fermer

STEP 2
ÉTAPE 2
PASO 2

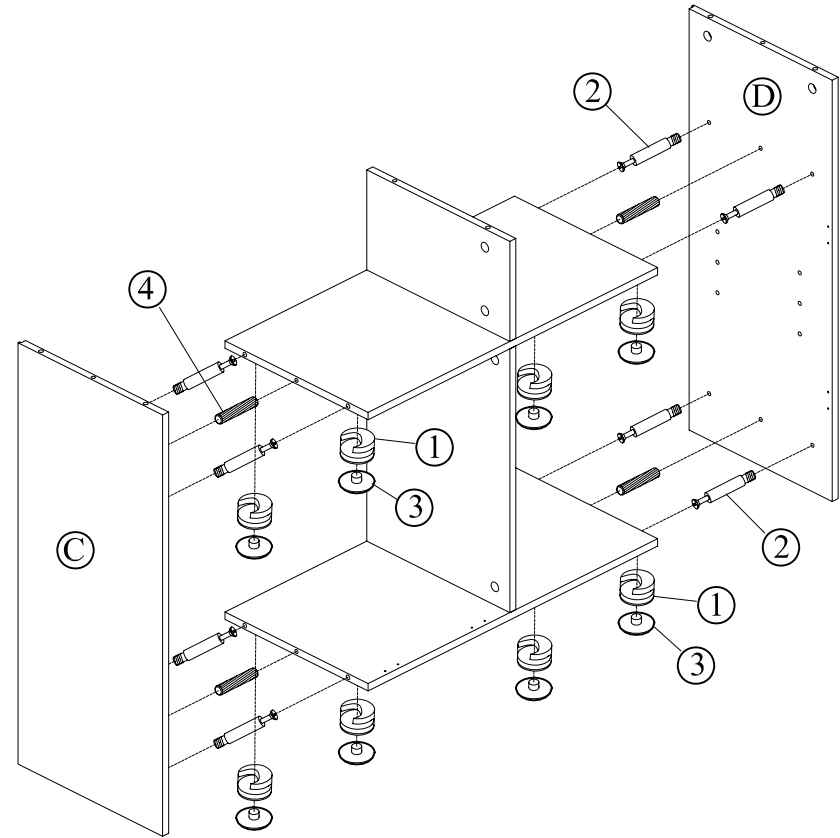

STEP 3
ÉTAPE 3
PASO 3

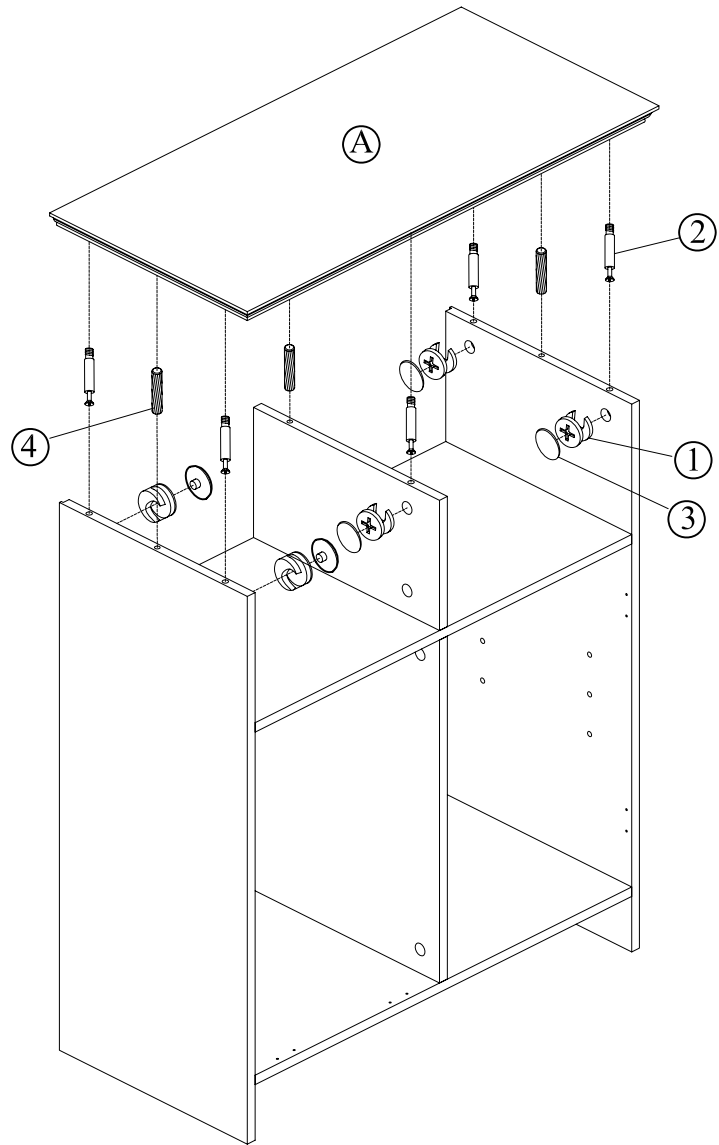

STEP 4
ÉTAPE 4
PASO 4

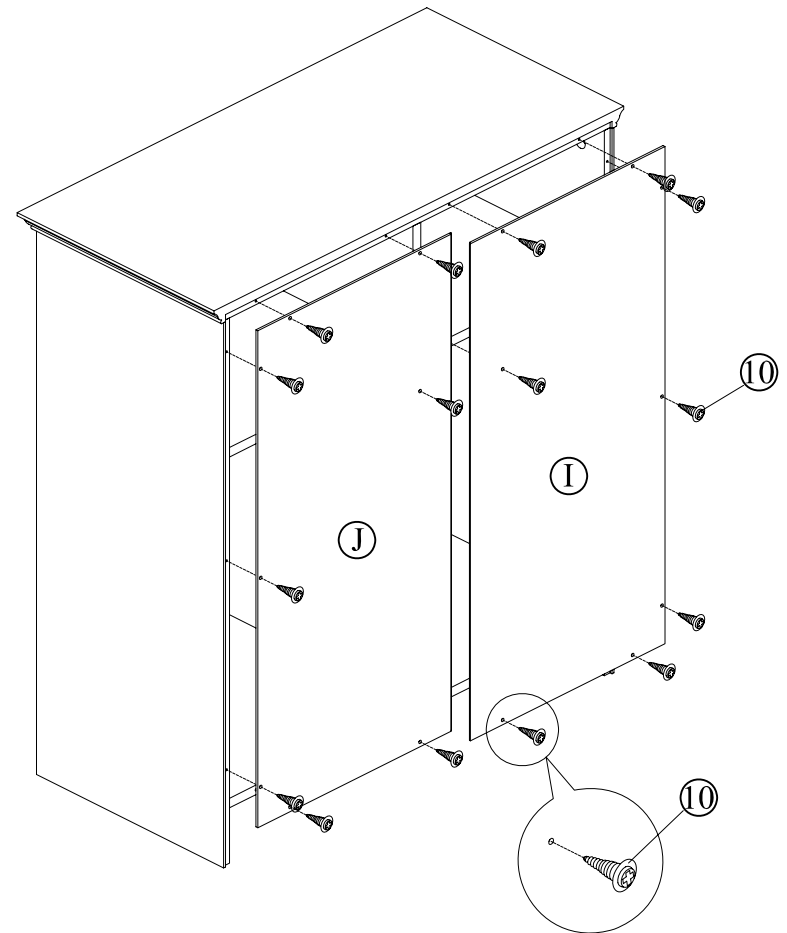

STEP 5
ÉTAPE 5
PASO 5

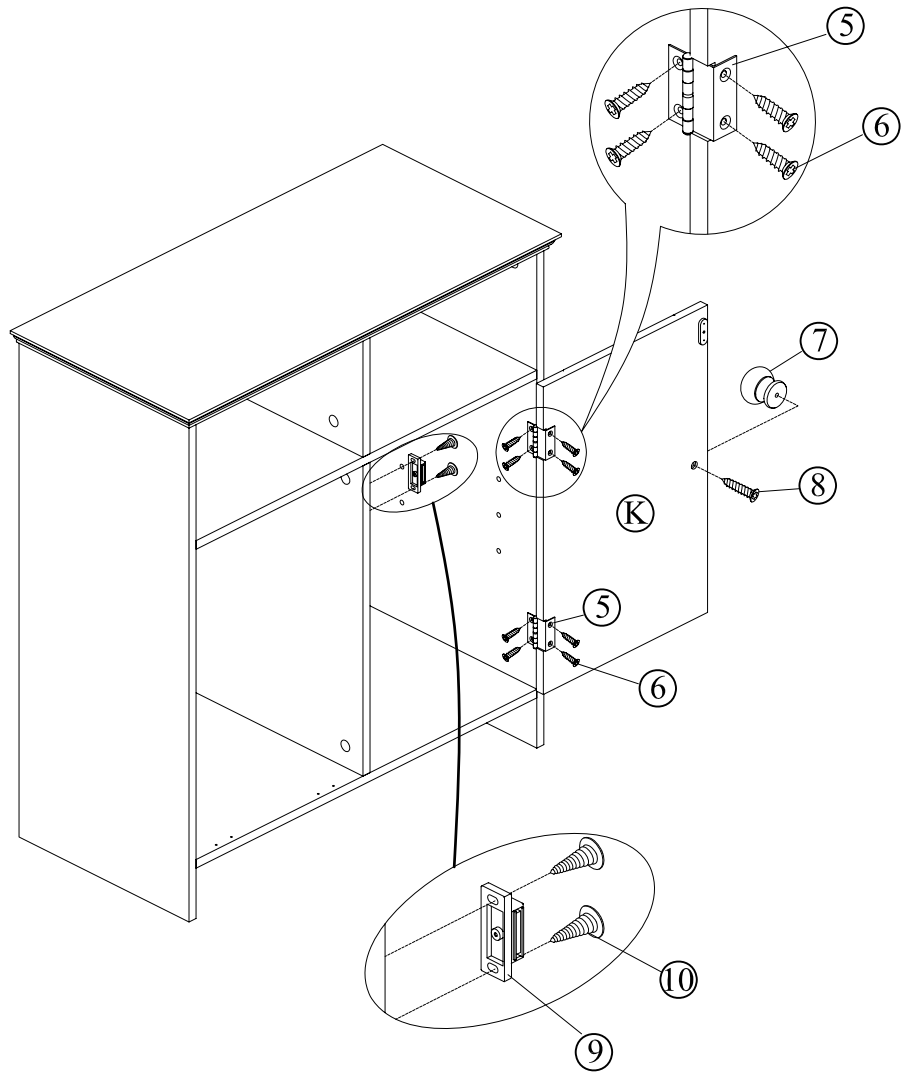

STEP 6
ÉTAPE 6
PASO 6

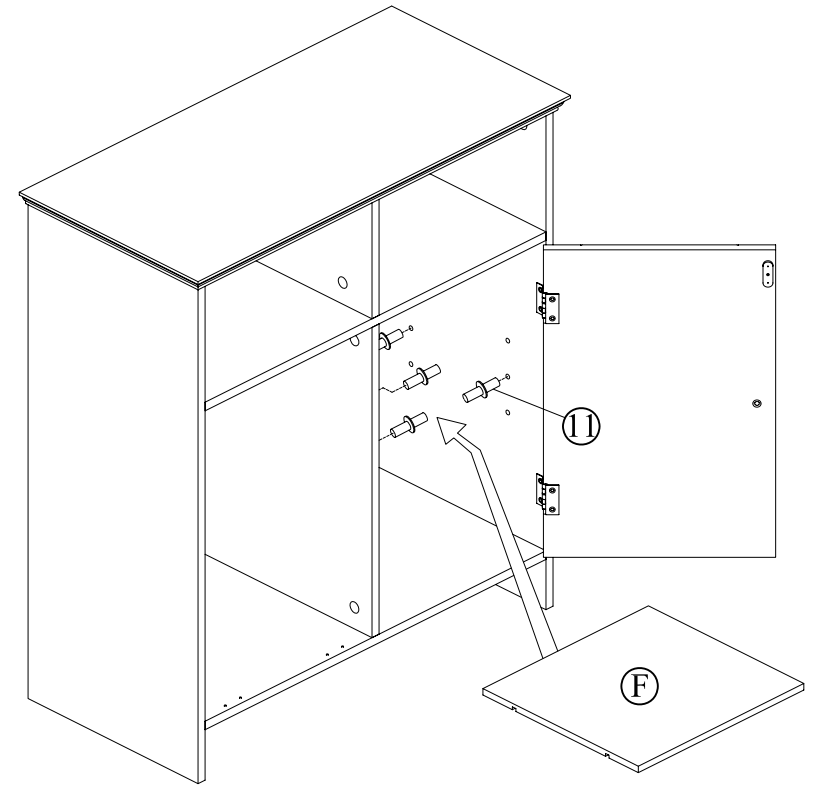

STEP 7
ÉTAPE 7
PASO 7

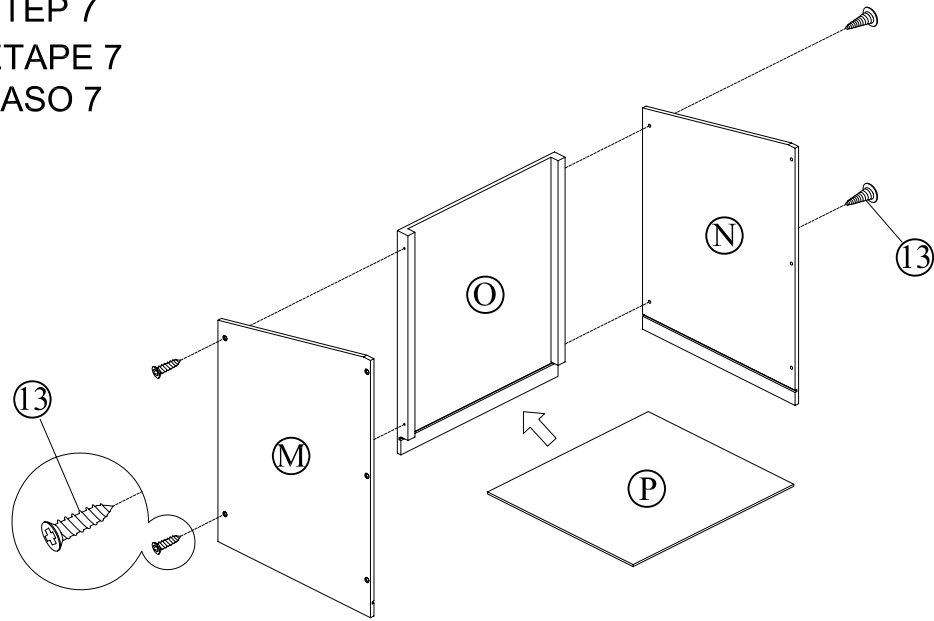

STEP 8
ÉTAPE 8
PASO 8

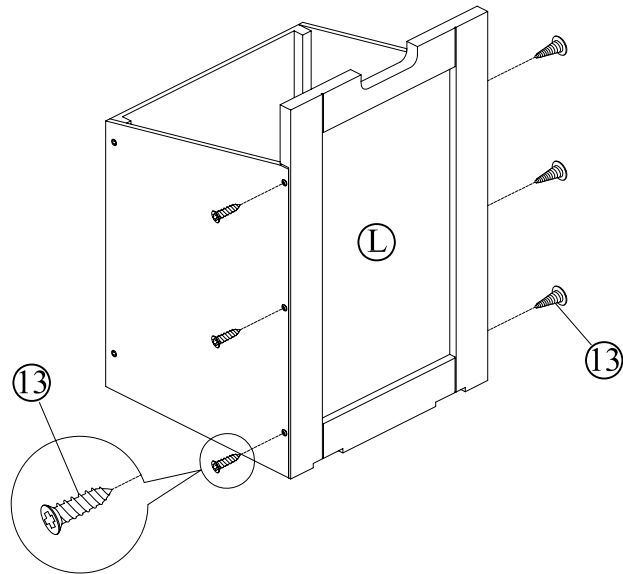

STEP 9
ÉTAPE 9
PASO 9

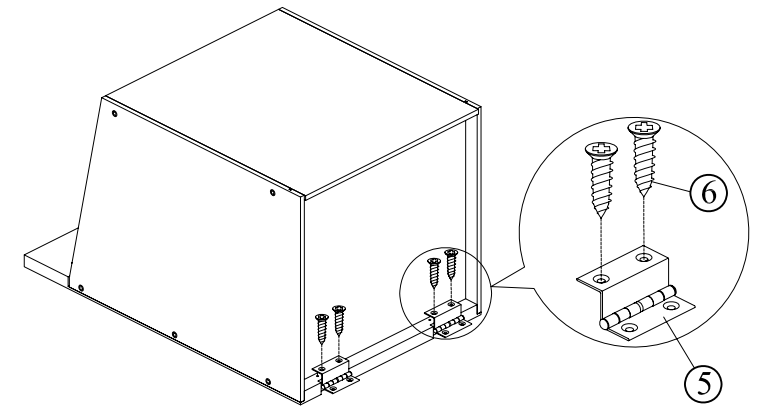

STEP 10
ÉTAPE 10
PASO 10

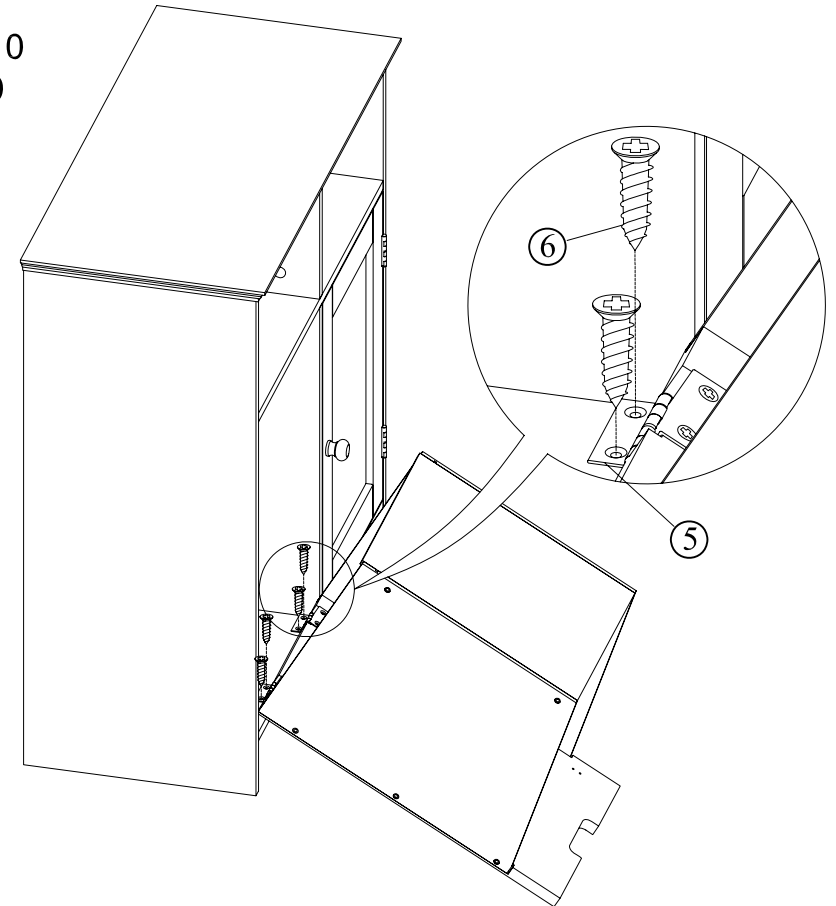

STEP 11
ÉTAPE 11
PASO 11

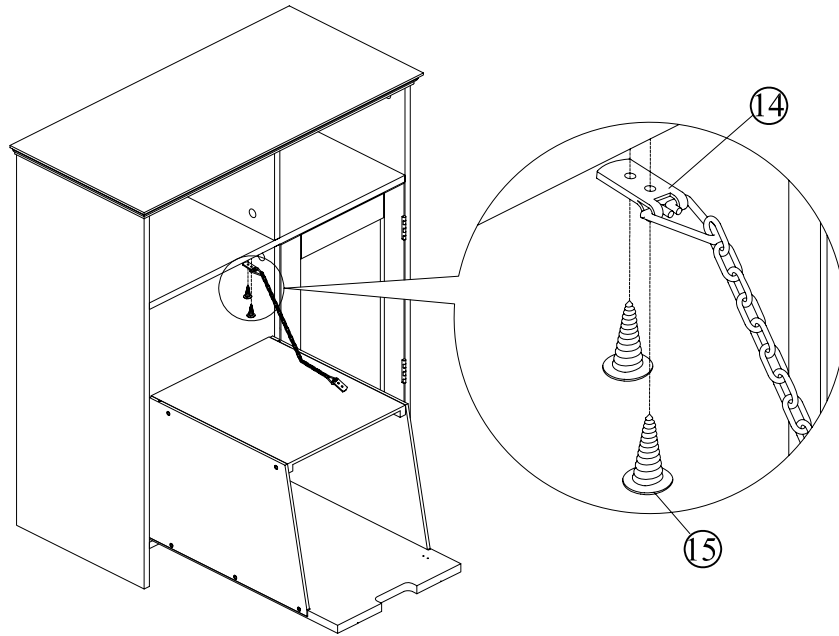

STEP 12
ÉTAPE 12
PASO 12

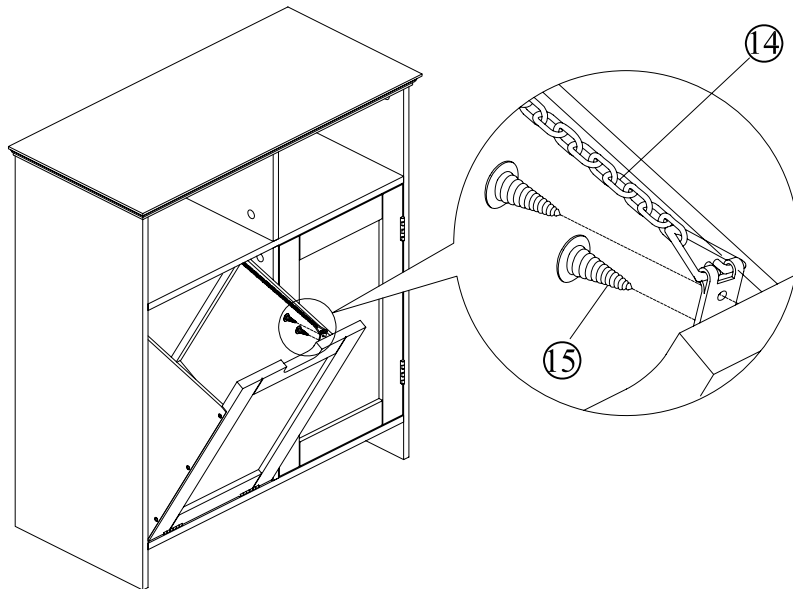

STEP 13
ÉTAPE 13
PASO 13

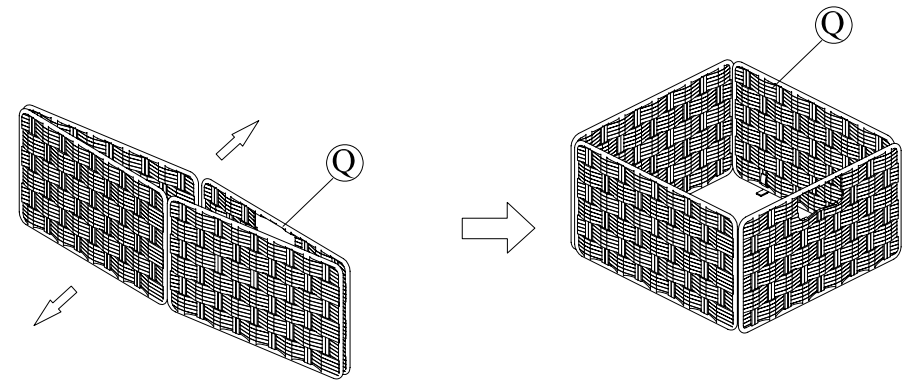

STEP 14
ÉTAPE 14
PASO 14

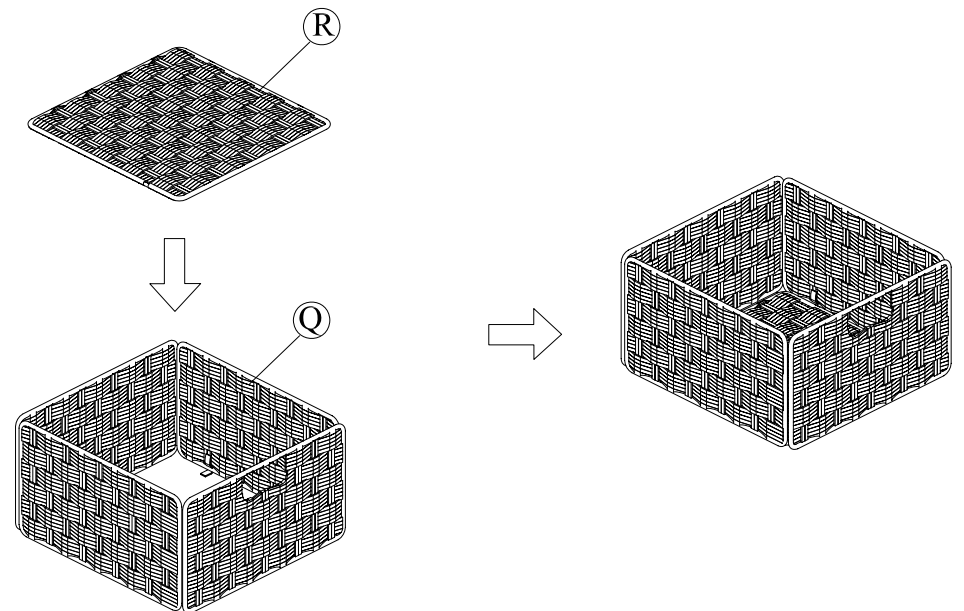

STEP 15
ÉTAPE 15
PASO 15

